

EYS-EZS-EZD-BMF-BMM-BFF

Sealing fittings and three pieces union



Installation

Hazardous areas – Zone 1 / 2 (Gases) – Zone 21 / 22 (Dusts)

Classification

Group II – Category 2G 2D

Reference standards

Directive 2014/34/EU	
Execution EYS - EZD	⚡ II 2 G Ex d IIC ⚡ II 2 D Ex tD A21 IP66
Execution EZS	⚡ II 2 G Ex db IIC T6 Gb ⚡ II 2 D Ex tb IIIC T85° Db IP66
Execution BMF-BMM-BFF	⚡ II 2 G Ex db IIB Gb ⚡ II 2 D Ex tb IIIC Db IP66/67 ⚡ II 2 G Ex db IIC Gb ⚡ II 2 D Ex tb IIIC Db IP66/67
Rules of compliance EYS - EZD	EN 60079-0; EN 60079-1; EN 61241-0; EN 61241-1
Rules of compliance EZS BMF-BMM-BFF	EN / IEC 60079-0; EN / IEC 60079-1; EN/IEC 60079-31
EU type-examination certificate	ICEPI 11 ATEX 03C002 (EYS-EZD sealing fittings) ITS-I 24 ATEX 38574X (EZS only sealing fittings) INERIS 12 ATEX 0069X (BMF-BMM-BFF three pieces union)
Protection degree	IP66 (sealing fittings) IP66/IP67 (three pieces union)
Ambient temperature	-20 °C ÷ +60 °C (sealing fittings) -60 °C ÷ +130 °C (three pieces union)
Other available certificates	IECEx: IECEx ITS 24.0015X (EZS only sealing fittings) IECEx: IECEx INE 12.0051X (BMF-BMM-BFF three pieces union) INMETRO: CEPEL 13.2243X (BMF-BMM-BFF three pieces union) EAC: TC RU C-IT.BH02.B.00587 (-60 °C ÷ +80 °C) UL NEC-505: 20131102-E465038 (BMF-BMM-BFF three pieces union) ECASEx: 23-06-22481/Q23-06-048569/NB0002

Sealing fittings – Mechanical characteristics

Material	Marine grade copper free aluminum light alloy
----------	---

Three piece unions – Mechanical characteristics

Material	Galvanized steel
Gasket	Silicon rubber EPDM

On Request Accessories

- Different threads from standard
- Different materials from standard

Technical Features

Sealing fittings

Detail "A"	Detail "B"	Detail "C"	ØD Hubs	
Type	Type	Type		
EYS1	EZS1	EZD1	1/2"	M20
EYS2	EZS2	EZD2	3/4"	M25
EYS3	EZS3	EZD3	1"	M32
-	EZS5	EZD5	1-1/2"	M50
-	EZS6	EZD6	2"	M63
-	EZS7	EZD7	2-1/2"	M75
-	EZS8	EZD8	3"	M90

Sealing table

Size	EYS	EZD	EZS
	Quantity [gr]	Quantity [gr]	Quantity [gr]
1	35	140	150
2	50	140	170
3	100	140	200
5	-	390	430
6	-	570	800
7	-	1000	1630
8	-	1000	1950

EYS-EZD Sealing fittings to be sealed by means of CRV-420 bi-component sealing compound - refer to Sealing table for quantities.
 EZS Sealing fittings to be sealed by means of RSN-C**** bi-component sealing compound - refer to Sealing table for quantities.

Bi-Component sealing compound

Type	Size	Description
RSN-C0200	200 gr	Two-component Epoxy resin, can size 200gr. with accessories
RSN-C0500	500 gr	Two-component Epoxy resin, can size 500gr. with accessories
RSN-C2000	2000 gr	wo-component Epoxy resin, can si ze 2000gr. with accessories

Sealing fittings are available in three basic forms:

- * EYS series for vertical conduits
- * EZS series for vertical and horizontal conduits
- * EZD series for vertical and horizontal conduits with drain and breather valve ECD included.

Three pieces union

Three piece union male/female ex d IIC			Three piece union male/male ex d IIC			Three piece union female/female ex d IIC		
Type	ØD	Detail	Type	ØD	Detail	Type	ØD	Detail
BMF1*	1/2"	D	BMM1*	1/2"	D	BFF1*	1/2"	E
BMF2*	3/4"	D	BMM2*	3/4"	D	BFF2*	3/4"	E
BMF3*	1"	D	BMM3*	1"	D	BFF3*	1"	E
BMF4*	1-1/4"	D	BMM4*	1-1/4"	D	BFF4*	1-1/4"	E
BMF5*	1-1/2"	D	BMM5*	1-1/2"	D	BFF5*	1-1/2"	E
BMF6*	2"	D	BMM6*	2"	D	BFF6*	2"	E
BMF7*	2-1/2"	D	BMM7*	2-1/2"	D	BFF7*	2-1/2"	E
BMF8*	3"	D	BMM8*	3"	D	BFF8*	3"	E

- * an alphabetic code (group of gas) to indicate in which kind of explosive atmosphere can be installed the accessory:
 - group of gas IIB: code "Empty" (ex. BMF2)
 - group of gas IIC: code "C" (ex. BMF2_C)

EYS

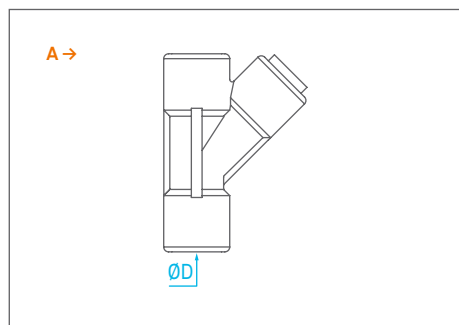

EZS

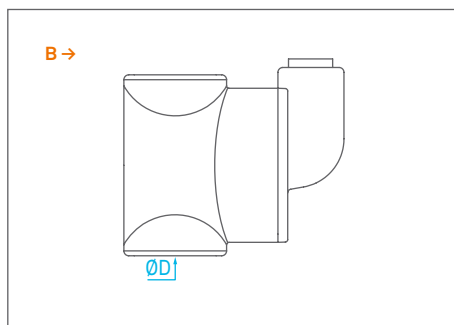

EZD

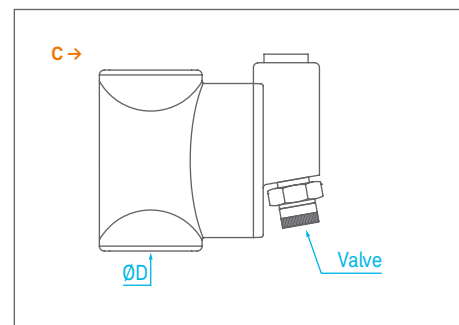

BMF - BMF_C - BMM - BMM_C

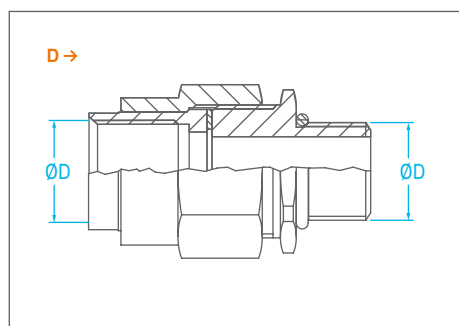

BFF - BFF_C

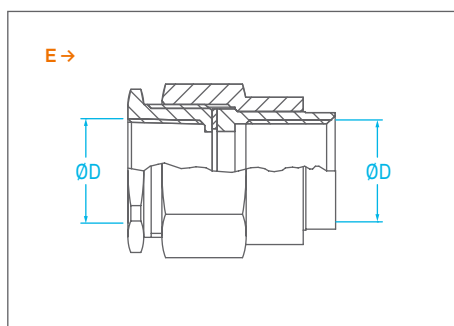

Cotton Wool Table

for Sealing fittings EYS - EZS - EZD

Size	Quantity (gr)
1	5
2	7
3	10
5	15
6	30
7	50
8	90



Used to dry up the compound resin during the sealing fittings process.

REMARK:

Due to the development of the national and international specifications and of the technology, the above technical characteristics showed on this bulletin can be considered as binding on our confirmation only.